

Shocker Testing Machine (Capacity-5000kg)



Dampening force of a shock absorber is directly proportional to velocity and this parameter needs to be precisely controlled. A small variation of 1mm in a stroke of 100 mm for 100rpm can result in a variation of 10% in **dampening** force.

For the precise control of frequency (rpm) and displacement **HEICO** has introduced electronically controlled hydraulic based Servo controlled close loop system with maximum Dampening force of 5 Tonnes.

A signal equivalent to frequency and amplitude is created in a function generator which is fed to the P.I.D. controller. Machine response signal is also fed to the P.I.D. controller. The error signal between the two signal creates differential pressure resulting in the movement of the actuator corresponding to programmed frequency and amplitude thereby completing the close loop.

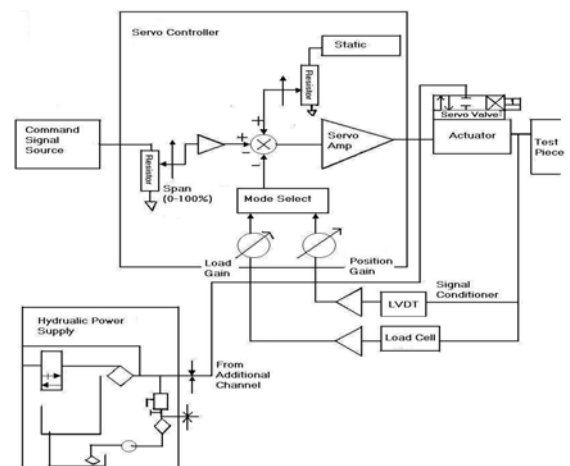

A typical test set up comprises of

1. Load Frame with side jacks including
 - a) Hydraulic Actuator (+/-5000kg)
 - b) Load Cell (+/-5000kg)
 - c) Displacement Transducer (+/-150mm/300mm)

2. Hydraulic Power Pack with Electrical Control Cabinet
3. Module with servo valve, high pressure filter, gas filled accumulators
4. Recording System includes
 - a) Signal Conditioning and Controlling Unit
 - b) Computer for Controlling and Data acquisition
 - c) Control and Analysis Software

1. LOAD FRAME WITH SIDE JACKS

It is a free standing load frame with two long vertical columns. Cross head with two hydraulic locking jacks slide over these columns and can be clamped anywhere over the entire length. Crosshead is lowered or raised by the side jacks with long travel. Controls are provided for lifting and lowering of the middle crosshead. Arrangement is also provided for locking of the crosshead at any desired position. Lower side of the middle plate carries the actuator with a built in LVDT where as load cell is fixed to the top crosshead. Manifold is provided at the base for proper distribution of oil to the actuator and hydraulic-lock.

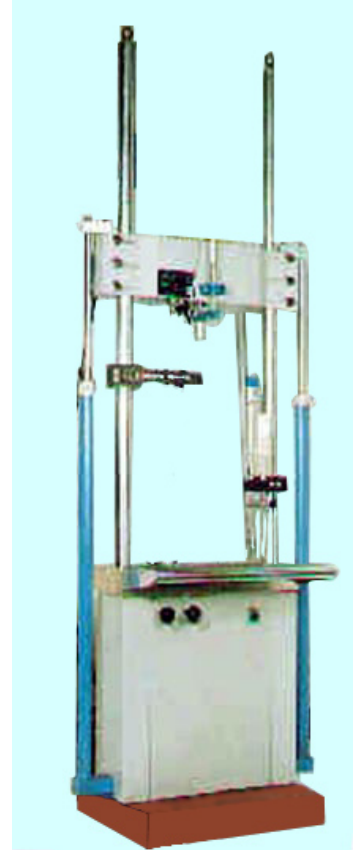

Capacity	:	5000kg
Horizontal clearance	:	500mm
Vertical clearance	:	1200mm
Capacity of the Actuator	:	5000kg
Displacement (Testing stroke length):	:	0-200mm

a) Actuator with Servo valve

Actuator is a linear motion device, which gives a controlled motion either on stress basis or strain basis. It is a precision piece of equipment which follows the command from the wave generator through the servo valve. It is an equal area ram and piston with surface finish of 0.2 microns. End plates have metallic seals for side thrust. Servo valve is fixed to the actuator. These valves are high performance two stage valves with a pressure drop of @ 70 bars. Other technical specifications are -



Type	:	Double Acting & Double ended
Load carrying capacity	:	+/-5000kg
Effective area	:	30 Sqcm
Stroke length	:	0-200mm
Operating pressure	:	180Bars

Servo valve 2 stage	:	95 LPM (72 series)
In built Displacement sensor	:	300mm (+/- 150mm*0.1mm)
Test Velocity	:	0 –40cm/sec or higher
Test frequency	:	0.01 – 10 Hz.

b) Load Cell

It is a strain gauge based type load cell with full wheat-stone bridge configuration. It has Alloy steel, electro less nickel plated structure for outstanding corrosion resistance. Structure of the load cell is such that it can be loaded in compression over few million numbers of times to test various type of shock absorbers. It has a over load capacity of 150% with a resolution of 1kg.

Technical Specification

Capacity	:	10Tons
Make	:	Adi-Artech
Full Scale Output	:	2.0 mV/V
Non-Linearity	:	< $\pm 0.05\%$ FSO
Hysteresis	:	< $\pm 0.05\%$ FSO
Non-Repeatability	:	< $\pm 0.05\%$ FSO
Creep (30 minutes)	:	< $\pm 0.03\%$ FSO
Excitation Voltage	:	10 Volts DC
Safe overload	:	150%
Operating Temperature	:	0 ^o C to +60 ^o C
Protection Class	:	IP68

c) Displacement Transducer

The variation in strain, deflection etc is measured with help of Micropulse Linear Transducer. Salient feature of Micropulse Transducer:

- Very high resolution, repeatability and linearity.
- Immunity to shock, vibration, contamination and electrical noise.
- An absolute output signal.
- Automatic signal regulation.
- 2 kHz update rate
- Resolution 0.1mm

Technical Specification

Range	:	300mm
Make	:	Gefran/Balluff
Full Scale Output	:	10.0 Volts
Independent Linearity	:	$\pm 0.02\%$ of FS
Repeatability	:	<0.01mm
Hysteresis	:	<0.01mm
Pressure Withstand	:	Up to 600 Bars
Excitation Voltage	:	24 Volts DC
Sampling Time	:	1ms
Operating Temperature	:	-30 ^o to +75 ^o C

Protection Class : IP67

2. HYDRAULIC POWER PACK

Hydraulic power supplies are compact in design and are suitable for the supply of required flow and pressure for the actuation of the actuator. It has a oil tank of adequate capacity, vane type pump powered by a three phase motor. All the electrical controls including the temperature controller are fixed on one side of the tank. It includes all the accessories like pressure line filter, return line filter, oil level, relief valve, pressure gauge and shell & tube type heat exchanger. Anti vibration mountings are provided as standard along with the HPS.



Broad specification of the system is:-

Flow of the pump	:	95lpm
Operating Pressure	:	180 Bars
Type of pump	:	Vane
Capacity of the oil tank	:	300litres
Power rating of the motor	:	50HP
Heat exchanger capacity	:	26,000 kcal/hr
Pressure line filter	:	3 microns or better
Return line filter	:	10 microns or better
Hoses	:	5 meter long
Electrical Cable	:	5meter long

All accessories like, pump pressure gauge, level gauge, pressure-line filter (3 microns) , return line filter (10 Microns) , digital temperature controller are provided as standard along with the system.

System will be supplied with necessary cable and fittings for the operation of the machine. Total machine operates on 440VAC 3 phase supply.

NOTE

1. Water supply at the rate of 100 lpm @ 30-35 degree celcius is to be provided by the consignee.
2. Power connection 3-phase equivalent to run 50HP motor is to be provided by the consignee.

ELECTRICAL CONTROL CABINET

This Electrical control Cabinet consisting of Electrical Components like:-

- (1) Contactors.
- (2) Time delay relays.
- (3) Power inlet.
- (4) Indicating lamps(RYB)

(5) Temperature Controller

and other electrical accessories are fixed inside the Electrical Control cabinet

3. MODULE WITH SERVO VALVE, HIGH PRESSURE FILTER, GAS FILLED ACCUMULATORS

This module carries state of the art **Servo Valve (72 Series)** fitted on a manifold. It has a high Pressure Line mesh filter at its inlet port. Two gas charged accumulators are fitted on A-B Port.



This module interfaces power pack and the actuator through pressure pipe lines and is fitted on to the actuator.

4. RECORDING SYSTEM

Control system provides the digital servo control, Ramp generation, different waveforms (Sine, Square & Triangular) for the machine, data acquisition, hydraulic control etc. for the continuous operation of the system.

(a) Signal Conditioning & Controlling Unit

HEICO **Servo controller** basically consists of signal conditioning unit and controlling unit. Signal conditioning unit receives the output signal from the various transducers and amplifies and process that signal as per the requirement and transfer it to computer through dedicated cables where it is accepted by the data acquisition system. The out put from the signal conditioning unit for each transducers range from 0-5V. The controlling unit controls the movement of the RAM with respect to the signal input on feed back basis either from LOAD CELL or DISPLACEMENT sensor.

It consists of dedicated servo-controller card that gives the desired processed signal through the P.I.D controller to the servo valve to operate either in strain mode or stress mode. It also sends the signal to computer and accepts the command from the software to operate in desired manner. The parameters like rate of loading for machine, safety limits for load & displacement can initially be programmed through the software. The programming facility is given to operate the system in **STATIC MODE** from **0.01mm/sec -400mm/sec. in displacement control** mode or **0.01kN/sec-1kN/sec in load** control mode. In **DYNAMIC MODE** the cycling can be done at a frequency from **0.1Hz-10Hz**.

(Note: - With the increase in frequency the amplitude (stroke) tend to decrease. However, **Performance curve** is attached for ready reference)

Specifications of Controller

- Auto PID operation with auto loop shaping servo operation
- Closed loop update rate is 10 kHz

- No. of control channels- 2
- Control Mode- Load/Displacement
- Demand generation - Sine, Triangular, Square and Ramp signal
- Standalone operation to Start, Stop & Hold the test system
- High speed Data Acquisition card with 100 kHz sampling rate and 16-bit resolution acquires data from the signal conditioning and controlling unit
- System accuracy- Load accuracy : $\pm 0.5\%$ of full Load capacity
Displacement accuracy: $\pm 0.5\%$ of full travel
- Two types of Loading- Dynamic (for fatigue test) and Static (Ramp)
- Dynamic Frequency Range- 0.01Hz to 10Hz (**Note: The stroke of actuator depends upon the frequency of operation. Performance curve enclosed for reference**)
- Static Ramp rate: Load control mode - 0.1kN/sec to 1kN/sec.
Displacement control mode- 0.01mm/sec to 400mm/sec.
- Environmental Temperature- 0°C to $+60^{\circ}\text{C}$
- Relative Humidity- 10% to 85% non-condensing
- Supply Input- 220-240 VAC, 50 Hz

(b) Computer for Controlling and Data acquisition

System is provided with dedicated computer with built in data acquisition card and wave generator. Broad specification of the computer and the data acquisition card is given below.

Computer

Intel P-IV Dual Core Processor,
1.8 Ghz or Higher, 160 GB HDD,
2 GB RAM, DVD R/W drive,
Key Board, Optical Mouse,
17" TFT Screen,
Deskjet Colored Printer
UPS 1KVA (APC Make)

Data Acquisition Card

The PCI Bus advanced data acquisition card provides the following advanced features

- 32 bit PCI- bus
- 16-bit Analog Input resolution
- Auto Scanning Channel selection up to 16 channels
- Up to 100 KHz A/D Sampling Rates
- 16 Single ended Analog Input channels
- Bipolar Input signals
- Programmable gain of x1, x2, x4, x8, x16
- Input range: $\pm 10\text{V}$, $\pm 5\text{V}$, $\pm 2.5\text{V}$, $\pm 1.25\text{V}$, $\pm 0.625\text{V}$
- One 12-bit Monolithic multiplying Analog Output channel
- 16 Digital Output and 16 Digital Input channels
- 4 extended Digital Input and Digital Output channels on the 37 - pin connector
- 3 Independent programmable 16-bit down counters.

- Three A/D Trigger modes: Software Trigger, Programmable Pacer Trigger and
- External Pulse Trigger
- Pre-trigger control
- Internal DC-to-DC converter for stable Analog power source.

c) CONTROL AND ANALYSIS SOFTWARE

Control software is the integral part of the system for precise controlling & Data Acquisition and analysis.

Salient Features

- Windows Xp based user friendly software
- Four different types of loading can be given to the sample- Sine, Triangular, Square, Random waveform and Ramp signal
- In Cyclic mode machine can go as high as 10 Hz (10 cycle/second) and as low as 0.01 Hz (0.01 cycle/second) covering **Test Velocity 0-40 cm/sec**.
- Programmable Loading parameters – Frequency, Base, Amplitude etc.
- Programmable rate of loading in static mode
- Two types of Tests- Dynamic (for fatigue test) and Static (Ramp).
- Defining test sequences
- Computer/Software programmable Safety Limits for each load & displacement
- Independent Taring of each channel
- Facility to hold the actuator and restart the loading during the test.
- Facility to increase the Base load, frequency and amplitude during the test
- Facility to save the data after the test
- Shows number of cycle on screen
- Store the number of cycles in Endurance test
- On-line display of command signal, load and displacement graphically.
- On-line display of Load and Displacement readings
- Auto adjustment of graph scales
- Facility to compare predefined values (design parameters) with specified tolerance to ascertain the suitability of the shock absorber
- Storing of data of each channel in user defined file/directory that can be directly opened in Excel and Analysis Software
- To analyze the test result Analysis software is given which shows different type of graph and data i.e. **Load Vs Displacement graph, Load Vs Time graph, Displacement Vs Time graph and Load Vs Speed graph** for statistical analysis.

Analysis Software

Analysis software provides flexibility to user to do statistical analysis of test results and report generation.

Salient features

- Plotting of following graphs-
 - a) Time v/s Load
 - b) Time v/s Displacement
 - c) Load v/s Displacement
 - d) Load v/s Speed
- Generation of various test results (Number of cycle adjustable (idle/acting), Maximum and minimum load etc.)
- Facility to plot the data for a single cycle
- Statistical analysis of the test results
- Detailed Summary Report
- Facility to take print out of the data and all the graphs
- Result Sheet generation